



## **SINGLE-ROOM REVERSIBLE ENERGY RECOVERY VENTILATOR**



**VENTO Expert A50-1 W V.2**  
**VENTO Expert A50C1-1 W V.2**  
**VENTO Expert A50-1 Pro3W V.2**  
**VENTO Expert A50C1-1 Pro3W V.2**  
**VENTO Expert A85-1 W V.2**  
**VENTO Expert A85-1 Pro3W V.2**  
**VENTO Expert A100-1 W V.2**  
**VENTO Expert A100C1-1 W V.2**  
**VENTO Expert A100-1 Pro3W V.2**  
**VENTO Expert A100C1-1 Pro3W V.2**  
**VENTO Expert Duo A30-1 W V.2**

**EN USER'S MANUAL**

**CONTENTS**

Safety requirements.....	2
Purpose.....	4
Delivery set.....	4
Designation key.....	4
Technical data.....	5
Design and operating principle.....	6
Mounting and set-up.....	9
Connection to power mains.....	12
Technical maintenance.....	20
Storage and transportation regulations.....	22
Manufacturer's warranty.....	23
Certificate of acceptance.....	27
Seller information.....	27
Installation certificate.....	27
Warranty card.....	27

This user's manual is a main operating document intended for technical, maintenance, and operating staff.

The manual contains information about purpose, technical details, operating principle, design, and installation of the VENTO Expert (Duo) A30/50/85/100(C1)-1 (Pro3) W V.2 unit and all its modifications.

Technical and maintenance staff must have theoretical and practical training in the field of ventilation systems and should be able to work in accordance with workplace safety rules as well as construction norms and standards applicable in the territory of the country.

**SAFETY REQUIREMENTS**

This unit is not intended for use by persons (including children) with reduced physical, sensory or mental capabilities, or lack of experience and knowledge, unless they have been given supervision or instruction concerning use of the unit by a person responsible for their safety. Children should be supervised to ensure that they do not play with the unit.

This appliance can be used by children aged from 8 years and above and persons with reduced physical, sensory or mental capabilities or lack of experience and knowledge if they have been given supervision or instruction concerning use of the appliance in a safe way and understand the hazards involved.

Cleaning and user maintenance shall not be done by children without supervision.

Children shall not play with the appliance.

Connection to the mains must be made through a disconnecting device, which is integrated into the fixed wiring system in accordance with the wiring rules for design of electrical units, and has a contact separation in all poles that allows for full disconnection under overvoltage category III conditions.

If the supply cord is damaged, it must be replaced by the manufacturer, its service agent, or similarly qualified persons in order to avoid a safety hazard.

Ensure that the unit is switched off from the supply mains before removing the guard.

Precautions must be taken to avoid the back-flow of gases into the room from the open flue of gas or other fuel-burning appliances.

The appliance may adversely affect the safe operation of appliances burning gas or other fuels (including those in other rooms) due to back flow of combustion gases. These gases can potentially result in carbon monoxide poisoning. After installation of the unit the operation of flued gas appliances should be tested by a competent person to ensure that back flow of combustion gases does not occur.

All operations described in this manual must be performed by qualified personnel only, properly trained and qualified to install, make electrical connections and maintain ventilation units. Do not attempt to install the product, connect it to the mains, or perform maintenance yourself. This is unsafe and impossible without special knowledge.

Disconnect the power supply prior to any operations with the unit.

All user's manual requirements as well as the provisions of all the applicable local and national construction, electrical, and technical norms and standards must be observed when installing and operating the unit.

Disconnect the unit from the power supply prior to any connection, servicing, maintenance, and repair operations.

Connection of the unit to power mains is allowed by a qualified electrician with a work permit for the electric units up to 1000 V after careful reading of the present user's manual.

Check the unit for any visible damage of the impeller, the casing, and the grille before starting installation. The casing internals must be free of any foreign objects that can damage the impeller blades.

While mounting the unit, avoid compression of the casing! Deformation of the casing may result in motor jam and excessive noise.

Misuse of the unit and any unauthorised modifications are not allowed.

Do not expose the unit to adverse atmospheric agents (rain, sun, etc.).

Transported air must not contain any dust or other solid impurities, sticky substances, or fibrous materials.

Do not use the unit in a hazardous or explosive environment containing spirits, gasoline, insecticides, etc.

Do not close or block the intake or extract vents in order to ensure the efficient air flow.

Do not sit on the unit and do not put objects on it.

The information in this user's manual was correct at the time of the document's preparation.

The Company reserves the right to modify the technical characteristics, design, or configuration of its products at any time in order to incorporate the latest technological developments.

Never touch the unit with wet or damp hands.

Never touch the unit when barefoot.

BEFORE INSTALLING ADDITIONAL EXTERNAL DEVICES, READ THE RELEVANT USER MANUALS.



**THE PRODUCT MUST BE DISPOSED SEPARATELY AT THE END OF ITS SERVICE LIFE.**

**DO NOT DISPOSE THE UNIT AS UNSORTED DOMESTIC WASTE.**

## PURPOSE

The ventilator is designed to ensure continuous mechanical air exchange in flats, cottages, hotels, cafés and other domestic and public premises. The ventilator is equipped with a regenerator that enables supply of fresh filtered air heated by means of extract air heat energy recovery.

The ventilator is designed for installation on external walls.

The ventilator is rated for continuous operation.

## DELIVERY SET

NAME	NUMBER	
	VENTO Expert	VENTO Expert Duo
Indoor assembly unit of the ventilator	1 pc.	1 pc.
Air duct	1 pc.	1 pc.
Air flow separator	-	3-6 pcs.
Silencer	1 pc.	-
Assembled cartridge	1 pc.	1 pc.
Outer ventilation hood	1 pc.	1 pc.
Remote control	1 pc.	1 pc.
Cardboard mounting plate	1 pc.	1 pc.
Mounting kit	2 packings	2 packings
Foam wedges	1 set	1 set
User's manual	1 pc.	1 pc.
Mounting hood installation instruction	1 pc.	1 pc.
Packing box	1 pc.	1 pc.

## DESIGNATION KEY

**VENTO Expert A -85 C1 -1 L Pro3 W V.2 BLK**

	<b>Color of indoor unit</b> _ – white BLK – black
	<b>Unit version</b> V.2: Wi-Fi controllable, connection to PC is not required
	<b>Control system type</b> W: Wi-Fi connection of ventilators
	<b>Availability of protective shutters</b> _: model with automatic protective shutters Pro3: model without automatic shutters, with manual blocking of air flow
	<b>The length of the duct</b> _ – 500 mm L – 700 mm L035 – 350 mm L1.0 – 1000 mm
	<b>Front panel modification</b> 1: flat front panel
	<b>Modification of the regenerator</b> _ – standard regenerator 150 mm long C1 – shortened regenerator 100 mm long
	<b>Rated air capacity [m<sup>3</sup>/h]</b>
	<b>Air duct section shape</b> A: round
	<b>Ventilator series</b> <b>Expert:</b> series of reversible ventilators with unidirectional air flow <b>Expert Duo:</b> series of reversible ventilators with bidirectional air flow

**TECHNICAL DATA**

The temperature in the room where the indoor unit of the ventilator is installed must be in the range from +1 °C to +40 °C with relative air humidity up to 80 % (no condensation build-up).

If the conditions of use of the ventilator are outside the specified limits, turn off the ventilator.

Provide fresh air supply through windows.

The temperature of the transported air should be in the range from -15 °C to +40 °C.

The ventilator is rated as a class II electric appliance.

Ingress protection rating against access to hazardous parts and water ingress is IP24.

The unit design is constantly being improved, thus some models may be different from those described in this manual.

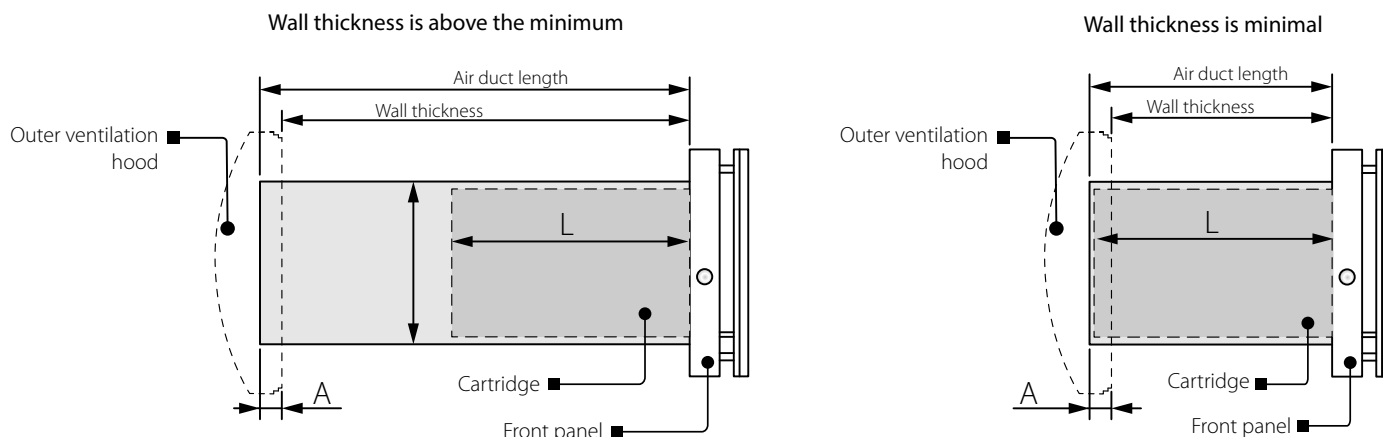

A: protruding part of the air duct on the outer wall.

L: length of the cartridge, depending on the model of the ventilator.

The length of the duct and the model of the supplied hood depend on the ventilator model (see Designation key).

The overall and connecting dimensions of the outer ventilation hood, the required outside protrusion length of the air duct A and the mounting sequence of the hood are stated in its mounting instruction.

Ventilator model	L, mm
VENTO Expert A50/85-1 W V.2	250
VENTO Expert A50C1-1 (Pro3) W V.2	220
VENTO Expert A100-1 (Pro3) W V.2	355
VENTO Expert A100C1-1 (Pro3) W V.2	310
VENTO Expert Duo A30-1 W V.2	280

The overall dimensions of the front panel are stated below.

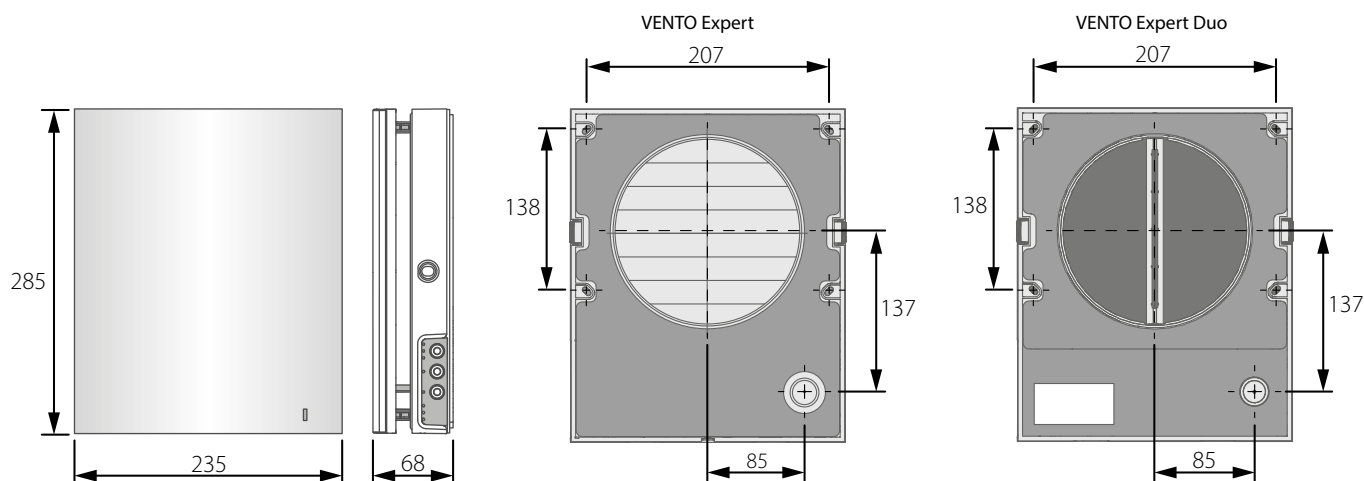

**Wi-Fi technical data**

Standard	IEEE 802.11b/g/n
Frequency band [GHz]	2.4
Transmission power [mW] (dBm)	100(+20)
Network	DHCP
WLAN security	WPA, WPA2

The technical data of the specific model are indicated on the label on the ventilator casing.



**DESIGN AND OPERATING PRINCIPLE**

The ventilator consists of an indoor unit with a decorative front panel, a cartridge, an air duct with a sound absorbing layer and an outer ventilation hood.

The cartridge is a basic functioning part of the ventilator. The cartridge consists of the fans, the regenerator and two filters that ensure rough air filtration and prevent ingress of dust and foreign objects into the heat exchanger and the fan.

The indoor assembly unit is equipped with automatic shutters that close during the ventilator standstill and prevent air backdraft.

The **VENTO Expert Duo** model has a set of air flow separators and an outer hood design that ensures that the exhaust and supply air flows are directed in different directions.

The outer ventilation hood is used to prevent direct ingress of water and other objects to the ventilator.

**VENTILATOR DESIGN**

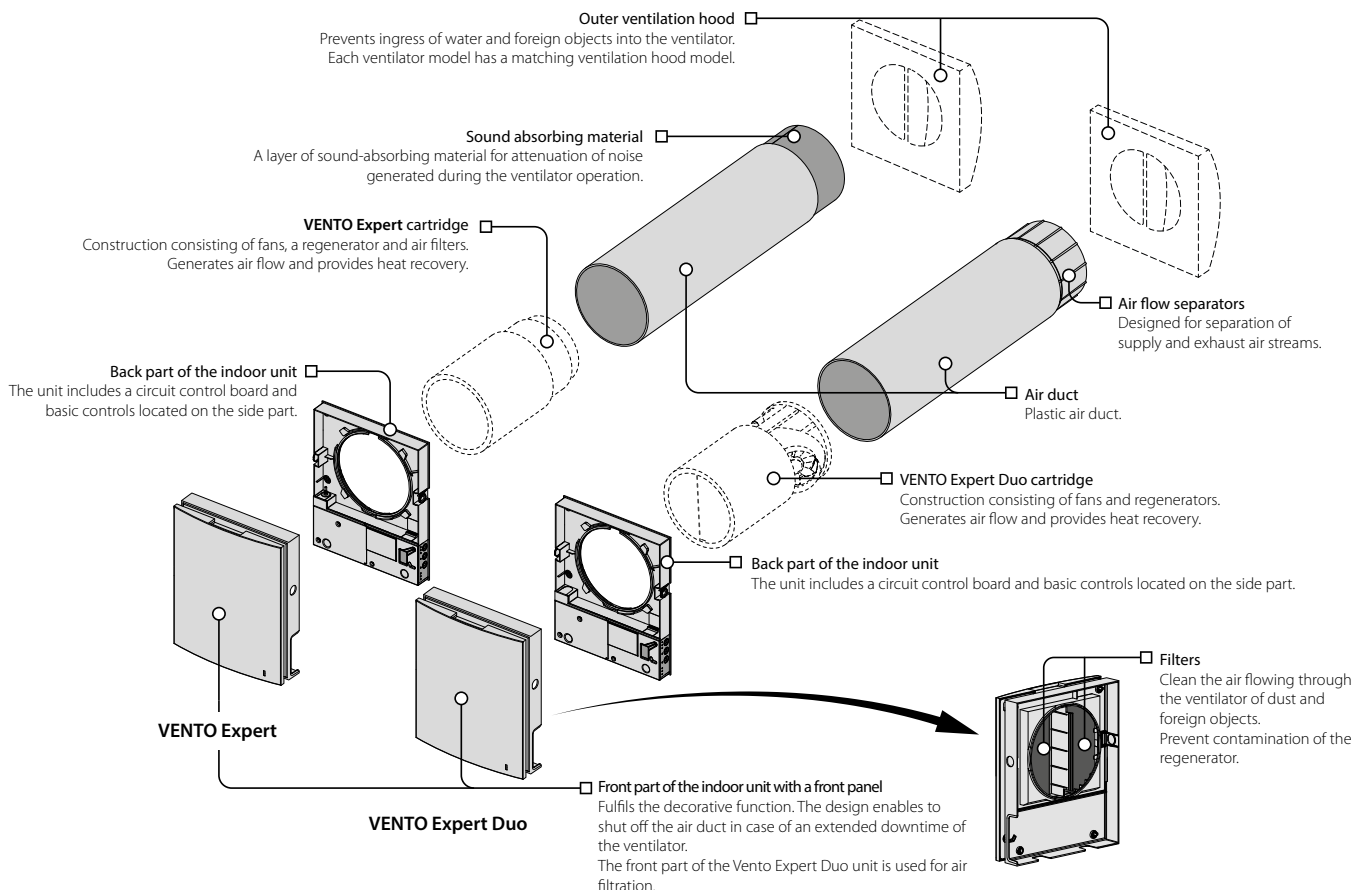

**OPERATING LOGIC OF THE AUTOMATIC SHUTTERS FOR VENTO Expert A30/50/85/100(C1)-1 W V.2**

The indoor unit of the VENTO Expert A30/50/85/100(C1)-1 W V.2 ventilators is equipped with automatic shutters. During the ventilator operation the automatic shutters are opened and let the air flow freely through the ventilator. The automatic shutters are closed for 2 minutes at the ventilator shut down.

The shutters are closed

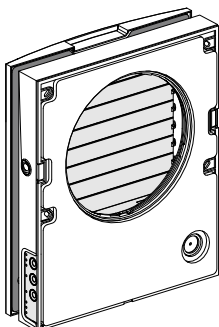

The shutters are open

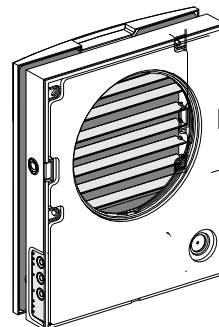

**AIR FLOW BLOCKING FOR THE VENTO Expert**

Press the front panel to close the air duct. The fan turns off automatically. The unit functionality is not changed.

To open the air duct, pull the front panel while holding the special recesses. The fan starts operating according to the actual speed setting.

Air duct shut-off

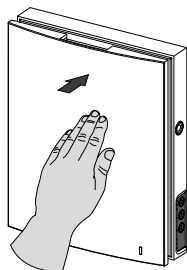

Air duct opening

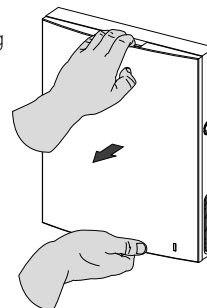

The front panel incorporates an operating LED indicator. During the dark time the indicator light intensity drops down.

**AIR FLOW BLOCKING FOR THE VENTO Expert Duo**

To close the air duct, unlatch and detach the front part of the indoor unit from its back part.

Then, gently unfasten the latches and separate the front part of the front panel. Pull out the airflow separator with filters by pulling on one of the side latches. Reinsert the front part of the front panel and gently push it in until it completely covers the duct.

The fan turns off automatically. The unit functionality is not changed.

Opening of the air duct is made in the reverse order. The fan starts operating according to the actual speed setting.

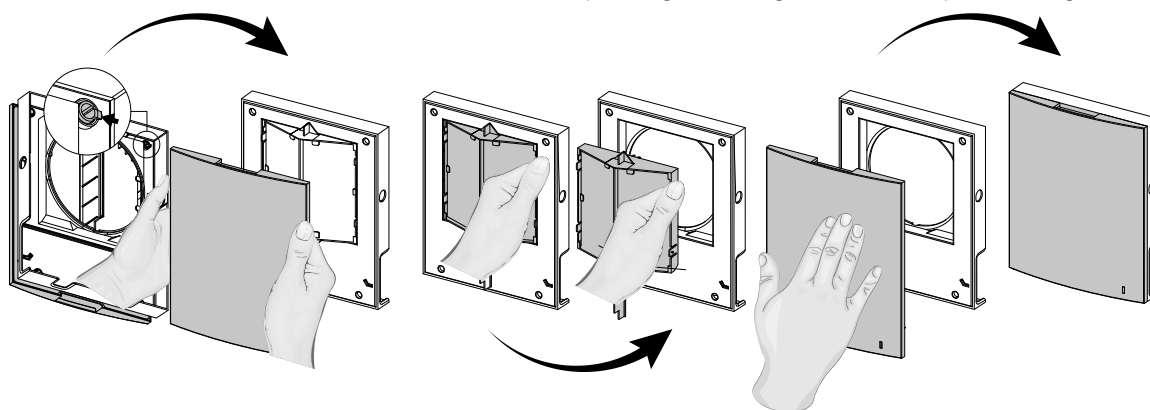

The front panel incorporates an operating LED indicator. During the dark time the indicator light intensity drops down.

## VENTILATOR OPERATION MODES

VENTO Expert	VENTO Expert Duo
<p><b>Ventilation</b> – the ventilator runs either in the air exhaust or air supply mode at a set speed.</p> <p>In this mode some of the ventilators in the network run in the air supply mode and the other ones in air exhaust mode, depending on the position of the DIP switch No. 3 (See section DIP switch positions).</p> <p><b>Air supply</b> (only available from a mobile device) - all ventilators in the group supply air regardless of the position of the DIP switch #3 (see the section “DIP switch positions”).</p> <p><b>Regeneration</b> – the ventilator operates in the reverse mode with heat and moisture regeneration, while it cyclically changes the direction of air flow.</p> <p><b>Cycle I.</b> Warm stale air is extracted from the room and flows through the ceramic regenerator, which gradually absorbs heat and humidity. In 70 seconds, as the ceramic regenerator gets warmed, the ventilator is switched to supply mode.</p> <p><b>Cycle II.</b> Fresh intake air from outside flows through the ceramic regenerator, absorbs accumulated moisture and is heated up. In 70 seconds, as the ceramic regenerator gets cooled down, the ventilator is switched to air extraction mode and the cycle is renewed. If two ventilators are installed, they operate with opposite rotation directions in this mode. While one ventilator supplies air, the other one extracts it.</p> <p><b>Boost</b> – the ventilator goes to the maximum speed without changing the operation mode.</p>	<p><b>Ventilation</b> – one of the fan fans exhausts air and the other supplies air at the selected speed without changing the direction of air flow.</p> <p><b>Regeneration</b> - one of the fans of the ventilator operates in the exhaust mode, while the other one operates in the supply mode. Each fan operates in the reverse mode with heat and moisture regeneration, cyclically changing the direction of air flow.</p> <p><b>Boost</b> - when the sensor is triggered, the ventilator executes one of two operation algorithms, which are set when setting up the ventilator using the DIP switch #3 (see the section “DIP switch position”). The DIP switch #3 is in the OFF position - the ventilator operates in the exhaust mode at the third speed (both fans are working to extract air). The DIP switch No. 3 in the ON position - the ventilator operates at maximum speed without changing the operating mode.</p>

The ventilators are equipped with an air humidity sensor and terminals for connecting an external 0-10 V analogue sensor and an external normally open contact (relay sensor). When either of these devices is triggered, the ventilator switches to the maximum speed (Boost mode).

When the sensors return to their original position, the Boost mode turn-off delay timer starts.

In the relevant sections of the Blauberg Home mobile application, you can configure the following ventilator operation parameters:

- enable or disable the humidity sensor, 0-10 V analogue sensor, and relay sensor;
- set the threshold for the humidity sensor and 0-10 V analogue sensor;
- set the duration of the Boost mode turn-off delay (30 minutes by default);
- set the duration of the first speed timer (“Night mode”) (8 hours by default);
- set the duration of the third speed timer (“Party mode”) (4 hours by default).

If necessary, in the “Schedule of the Blauberg Home mobile application” section, you can set different speeds of the ventilator at different time intervals by day of the week. For the weekly schedule to work correctly, you must set the current date and time correctly in the “Date and time” section.

When simultaneously activating several operation modes that exclude each other, the ventilator selects the mode according to the following priority:

1. Night mode timer or Party mode timer.
2. Standby.
3. Boost.
4. Weekly Schedule.
5. Standard operation mode.



**MOUNTING AND SET-UP**



**READ THE USER'S MANUAL BEFORE INSTALLING THE UNIT**



**DO NOT BLOCK THE AIR DUCT OF THE INSTALLED VENTILATOR WITH DUST ACCUMULATING MATERIALS, SUCH AS CURTAINS, CLOTH SHUTTERS, ETC. AS IT PREVENTS AIR CIRCULATION IN THE ROOM.**

1. Prepare a round core hole in the outer wall. The hole size is shown in the figure below.

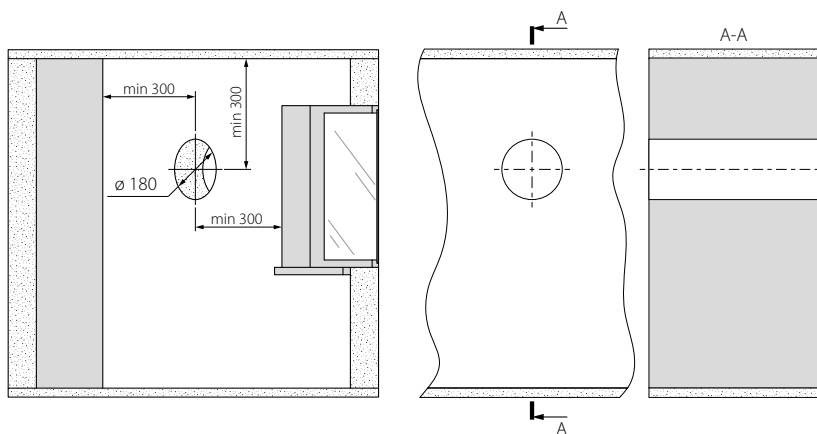

2. Insert the air duct in the wall hole. For ease of installation use the polystyrene wedges included in the delivery set. The air duct end must protrude for the distance A that enables installation of the outer ventilation hood. The distance A is stated in the installation instruction for the ventilation hood.

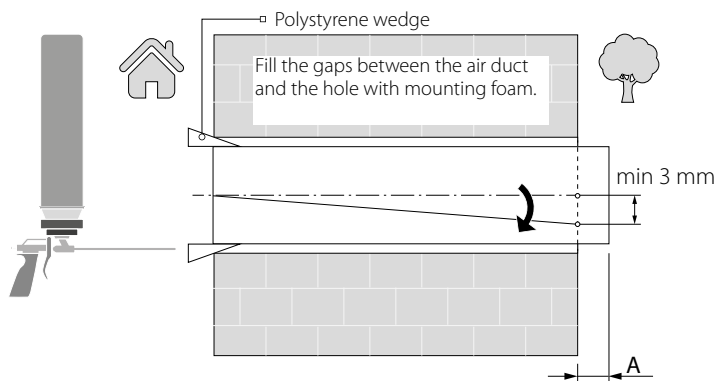

When installing the air duct, ensure that the slope towards the street is at least 3 mm downwards.

To cut the air duct either make preliminary calculations of the required duct length or make sure to have access to the outer wall after fixation of the air duct.

3. Fasten the supplied mounting template to the indoor wall using the adhesive tape. The large opening in the template must be coaxial with the air duct. For aligning the template with respect to the horizon line it is recommended to use a builder's level. Then mark the fastening holes for installation of the supplied dowels and drill the holes to a required depth. Route the power cable of the ventilator from the wall through the marked opening on the template.

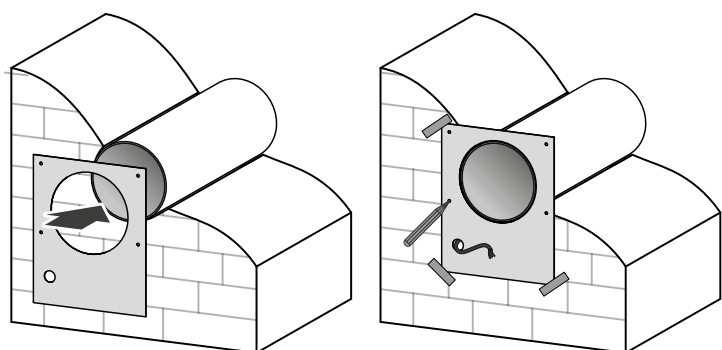

**Hole marking for fan fastening**

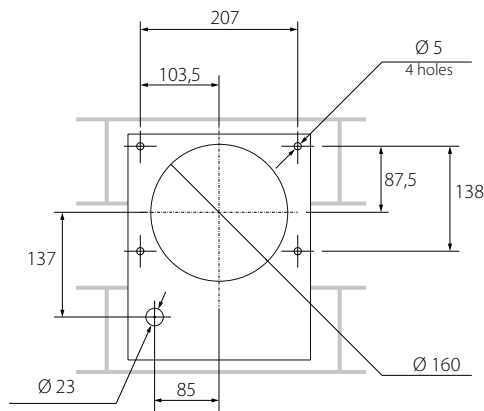

4. Press the side tabs to detach the front part of the indoor unit from its rear part.

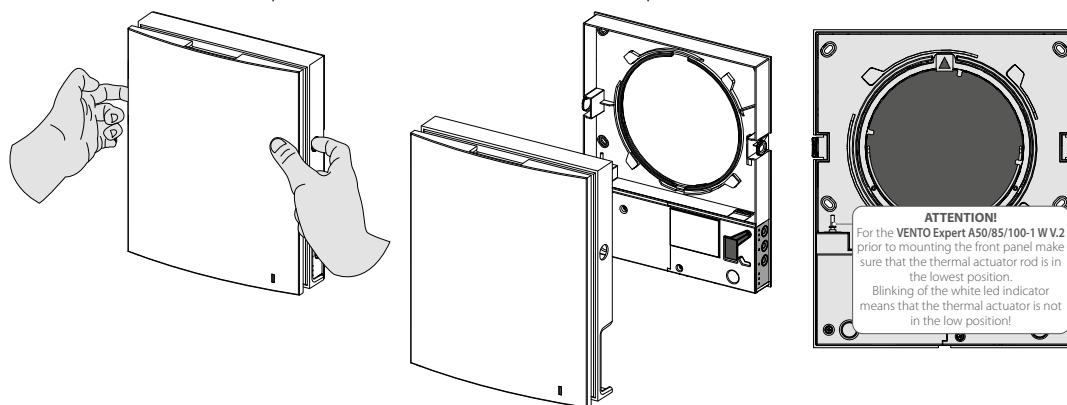

5. Fix the rear part of the indoor unit on the wall using the screws supplied with the mounting kit of the ventilator. Remove the two screws that retain the transparent cover to enable access to the connection terminals.

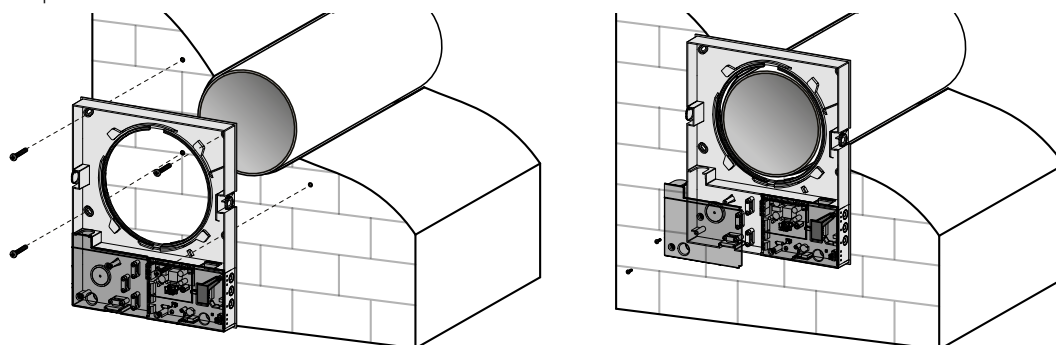

6. Route the power cable as figured below and connect the ventilator to power mains in compliance with the external wiring diagram.

Fix the power cable and the signal cables with a cable clamp. After completion of the electrical connection re-install the transparent terminal cover in site.

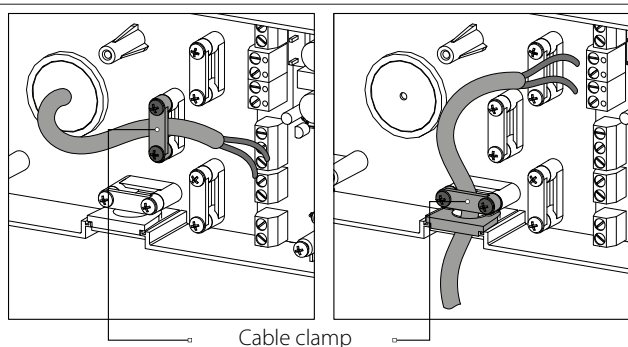

7. Insert the cartridge in the air duct as shown below. During mounting make sure the pointer is directed upwards. Then fix the cable with a clamp and connect the socket connector to the control board.

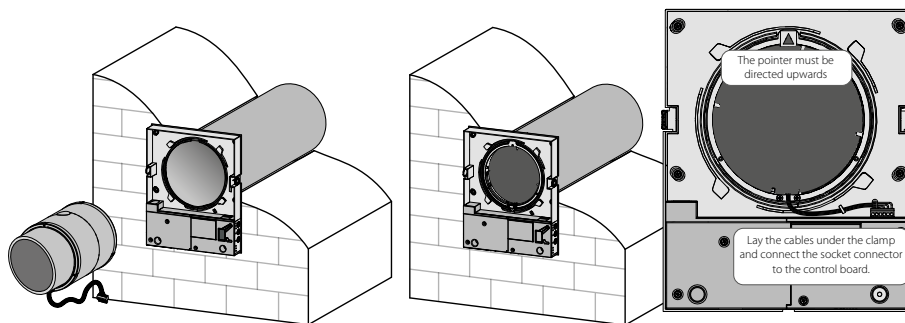

8. Install the front part of the indoor unit.

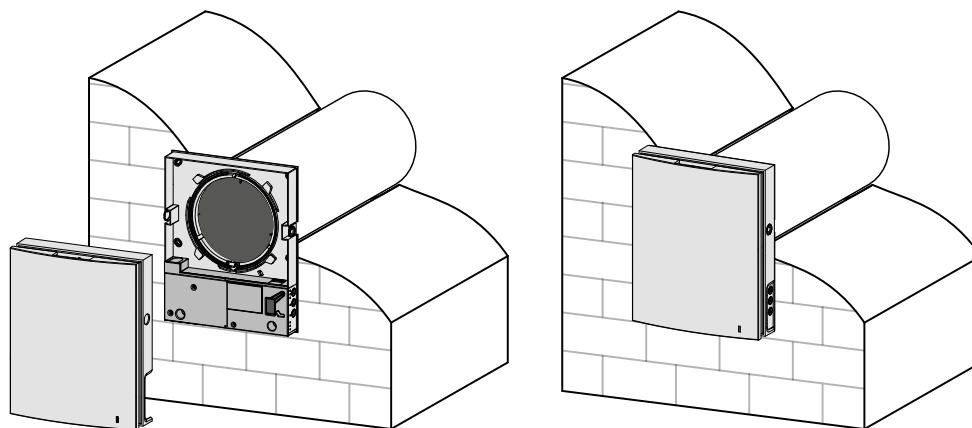

**VENTO Expert**

9. Insert the sound absorbing mat into the air duct. Roll the sound absorbing mat to match the air duct diameter with the protecting paper layer outside. Insert the roll in the air duct against stop to the cartridge. Make a mark at the end of the air duct, remove the sound absorbing mat and cut the roll according to the marking. After that insert the ready roll into the air duct.

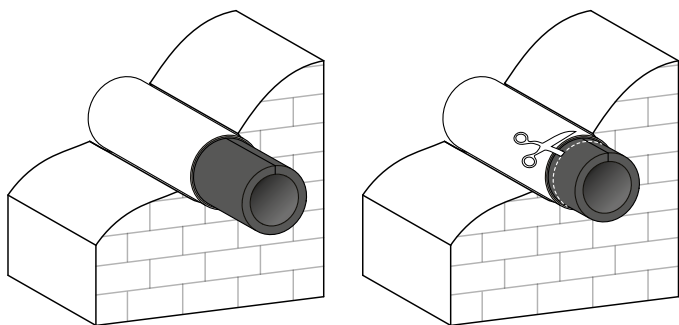

**VENTO Expert Duo**

9. Install the sectional air flow separators from outside. Install a required number of the air flow separators in the air duct against stop to the cartridge. Mark the last air flow separator to be flush with the air duct face, remove the last air flow separator from the air duct and cut it according to the marking. Install the adjusted air flow separators to the air duct.

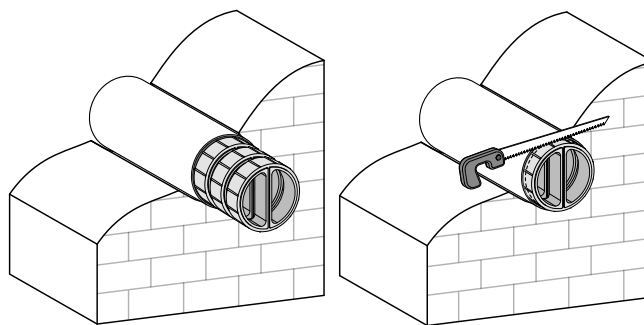

10. Install the outer ventilation hood. For mounting guidelines of the ventilation hood please refer to the installation instruction for the outer hood.

**CONNECTION TO POWER MAINS**

**POWER OFF THE POWER SUPPLY PRIOR TO ANY OPERATIONS WITH THE UNIT. THE UNIT MUST BE CONNECTED TO POWER SUPPLY BY A QUALIFIED ELECTRICIAN. THE RATED ELECTRICAL PARAMETERS OF THE UNIT ARE GIVEN ON THE MANUFACTURER'S LABEL.**

**ANY TAMPERING WITH THE INTERNAL CONNECTIONS IS PROHIBITED AND WILL VOID THE WARRANTY.**

The ventilator is rated for connection to single-phase AC 120 V ~ 60 Hz power mains.

The routing of the power and signalling cables is shown in the "Mounting and set-up" section.

For electric installations use insulated, durable and heat-resistant conductors (cables, wires) with the general cross section of 0.5 up to 0.75 mm<sup>2</sup> for a power cable and 0.25 mm<sup>2</sup> for signal cables.

The cable cross-section is given for reference only. The signal cable must be shielded.

The actual conductor cross-section selection must be based on its type, maximum permissible heating, insulation, length and installation method. Use copper wires for all the electric connections!

Connect the unit to power mains via the terminal block installed in the control board in compliance with the wiring diagram and terminal designation.

Connect the ventilator to power mains through an automatic circuit breaker with magnetic trip integrated into the home wiring system. The tripping current of the circuit breaker must correspond to the current consumption (see the label on the ventilator casing).

The ventilator design enables connecting any external controls with a normally opened contact (NO contact), such as an external CO<sub>2</sub> sensor, a humidity sensor, a switch, etc.

When the NO contact of the external device is closed, the unit changes to the maximum speed.

An analogue sensor with output voltage 0-10V is also compatible with the unit.

The diagrams below show two options for connecting the ventilator to the power supply depending on the location of the terminals on the board.

Use the one that corresponds to the location of the terminals on your ventilator.

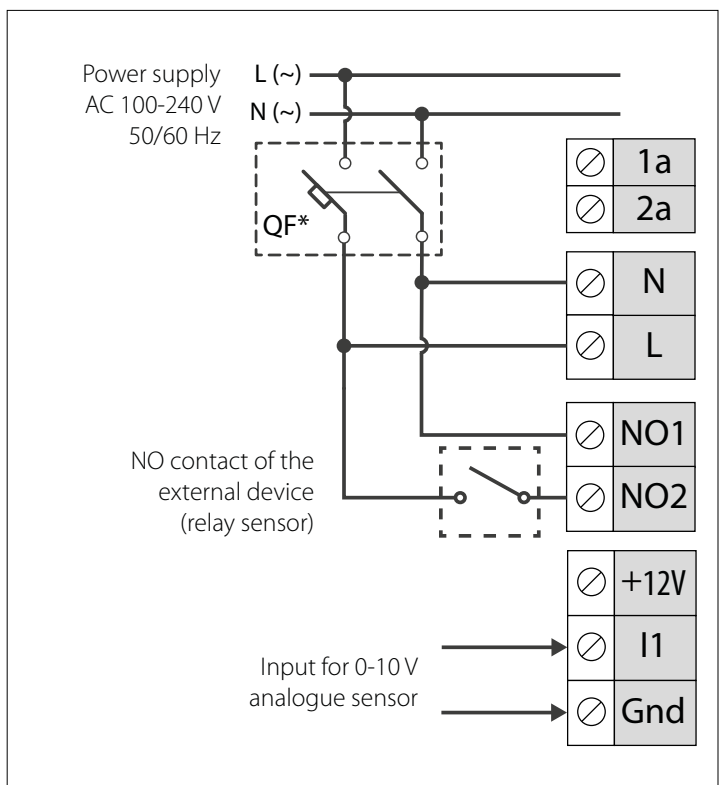
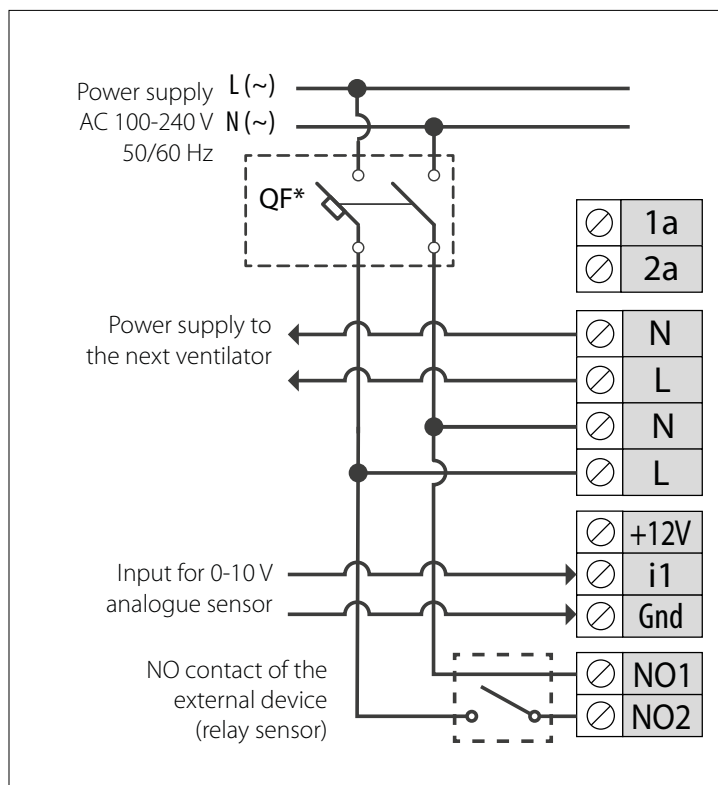

**PRE-SETTING OF THE VENTILATOR**

Prior to operating the ventilator set it up using the DIP switch. It is located on the controller circuit board. To access the DIP switch, take off the front panel of the indoor unit and uplift the rubber plug that covers the switch.

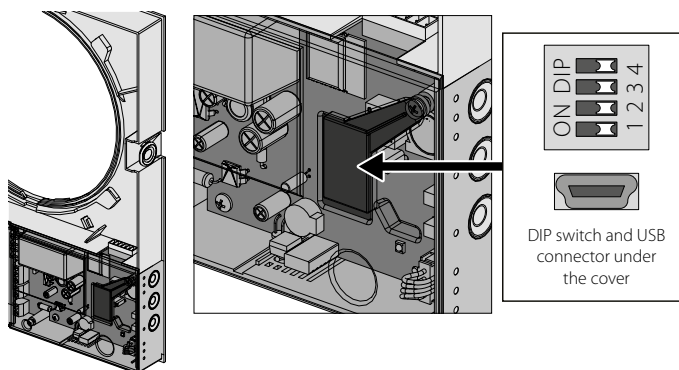

**POSITIONING OF THE DIP SWITCHES**



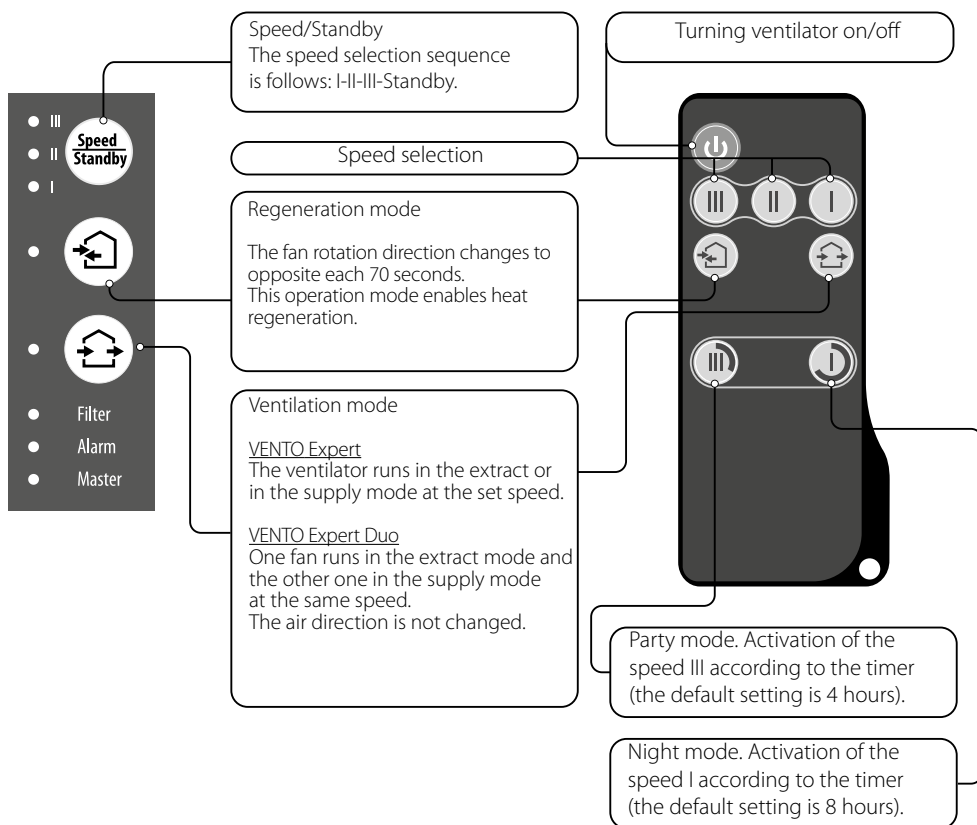

<b>Defining the role of the ventilator when operating in a group</b>	
<input type="checkbox"/> 1	OFF - primary unit (hereinafter referred to as " <b>Primary</b> unit")
<input checked="" type="checkbox"/> 1	ON - secondary unit (hereinafter referred to as " <b>Secondary</b> unit")
<b>Standby mode setup</b>	
<input type="checkbox"/> 2	OFF - the ventilator is switched off in the Standby mode.
<input checked="" type="checkbox"/> 2	ON - the ventilator operates at Speed I in the Standby mode.
<b>Adjusting the airflow direction of the VENTO Expert in Ventilation mode and when working as part of a group</b>	
<input type="checkbox"/> 3	OFF - operation in air extraction mode.
<input checked="" type="checkbox"/> 3	ON - operation in air supply mode.
<b>Setting the Boost mode (when any of the sensors is triggered) for the VENTO Expert Duo model</b>	
<input type="checkbox"/> 3	OFF - when the sensor is triggered, the fan operates in the exhaust mode at the third speed.
<input checked="" type="checkbox"/> 3	ON - if the sensor is triggered, the fan operates in the current mode at the third speed.
<b>Restore factory default settings</b>	
<input type="checkbox"/> 4	OFF - standard operation of the unit.
<input checked="" type="checkbox"/> 4	ON - restore factory default settings. For this purpose, move the switch on the operating ventilator to the ON position, after the sound signal turn the switch to the OFF position.

The figure below shows the control buttons on the indoor unit and the remote control with a brief description of their function.









**VENTILATOR CONTROL WITH THE BUTTONS ON THE INDOOR UNIT**

The table below shows the buttons and indicators on the indoor unit of the ventilator with a detailed description of their purpose and functionality.

	<p>The speed selection sequence is follows: I-II-III-Standby. All the units integrated in a single network operate according to the speed settings of the Master unit.</p> <p><b>I:</b> permanent indicator glowing indicates operation of the unit at Speed I. Indicator blinking indicates activation of the Night mode timer.</p> <p><b>I and II:</b> permanent glowing of the indicators I and II indicates running of the ventilator at the medium speed.</p> <p><b>I, II and III:</b> permanent glowing of the indicators I, II and III indicates running of the ventilator at the high speed. Synchronous blinking of the indicators I, II and III indicates activation of the timer in Party mode or the turn-off delay timer in the Boost mode in case of actuation of the connected external sensors or the integrated humidity sensor.</p> <p>Alternate blinking of the indicators I, II and III indicates that the ventilator runs at the speed set with the mobile application using the slider selector for manual speed setting or that the Weekly Schedule mode is activated.</p>
	<p><b>Regeneration mode</b>  <u>VENTO Expert</u>                  The rotation direction of both fans changes to opposite every 70 seconds. Heat recovery is performed in this mode. To enable reverse phase operation of the ventilators, change the position of DIP switch No. 3.</p> <p><u>VENTO Expert Duo</u>                  The rotation direction of both fans changes to opposite every 70 seconds. Heat recovery is performed in this mode.</p>
	<p><b>Ventilation mode</b>  <u>VENTO Expert</u>                  The ventilator operates in the supply or extraction mode at a set speed. The fan rotation direction depends on the position of the DIP switch 3.</p> <p><u>VENTO Expert Duo</u>                  One of the ventilator fans operates in exhaust mode, the other in supply mode at the selected speed without changing the direction of air flow.</p>
<p>No glowing of the indicators <b>“Regeneration”</b> and <b>“Ventilation”</b> indicates forced operation of the ventilation unit in the air supply mode. This mode may be activated only via the mobile application.</p>	
<p><b>Filter</b></p>	<p>90 days after installation of the cartridge the filter replacement indicator starts glowing. In this case, clean or replace the filters (see section Technical maintenance).</p> <p>After replacement of the filters reset the timer using the mobile application or by pressing and holding the</p>  <p>button on the Master ventilator indoor unit for 5 seconds until a signal sounds.</p>
<p><b>Alarm</b></p>	<p>Alarm indicator.                  In case of failure, the Alarm indicator on the indoor unit glows or blinks.                  Reasons of Alarm blinking:                  Battery charge is below the low level.                  No connection between the Master unit and the router.                  Alarm shutdown of the ventilator.                  If several interconnected ventilators are running in the group, in case of alarm shutdown of the VENTO Expert ventilator, all of the ventilators of this group also stop. The alarm indicator blinks on the defective ventilator and glows on the other connected ventilators.                  At the same time, the ventilators of the VENTO Expert Duo series included in this group continue to operate.                  In case of an emergency shutdown of the VENTO Expert Duo series ventilator, the faulty ventilator does not affect the operation of other ventilators in the same group.                  In case of communication loss of the Master unit with the router for longer than 20 seconds, the Master unit switches to <b>Standby</b> mode (<b>Alarm</b> indicator blinking) and the Slave units will signal that there is no communication with the Master unit (see the description of the Master indicator).                  After resuming communication, the Slave units are automatically synchronised with the Master unit.</p>
<p><b>Master</b></p>	<p>Permanent glowing of the indicator shows the leading unit in the network (<b>Master</b> unit).                  Indicator blinking indicates the driven unit (Slave unit) and no connection to the Master unit.                  No glowing of the lamp indicator means that this ventilation unit is a Slave ventilation unit and it is connected to a <b>Master</b> unit.</p>
<p>Synchronous blinking of all the lamp indicators on the casing of the ventilator indicates that the Setup mode is enabled.</p>	

### REMOTE CONTROL OF THE VENTILATOR

The table below shows the buttons on the remote control with a detailed description of their purpose and functionality.

	ON/Standby. The <b>Standby</b> mode depends on the position of the DIP switch #2 (see "DIP switch position" section). The same button is used to reset alarms ( <b>Alarm</b> ) and turn off the timers.
	Ventilator speed selection: Speed III-II-I respectively.
	<b>Regeneration mode</b> <u>VENTO Expert</u> The rotation direction of both fans changes to opposite every 70 seconds. Heat recovery is performed in this mode. The fan rotation direction depends on the position of the DIP switch 3. <u>VENTO Expert Duo</u> The rotation direction of both fans changes to opposite every 70 seconds. Heat recovery is performed in this mode.
	<b>Ventilation mode</b> <u>VENTO Expert</u> The ventilator operates in the supply or extraction mode at a set speed. The fan rotation direction depends on the position of the DIP switch 3. <u>VENTO Expert Duo</u> One of the ventilator fans operates in exhaust mode, the other in supply mode at the selected speed without changing the direction of air flow.
	Timer control buttons:  <b>Party mode:</b> the timer activates operation of the ventilation unit at Speed III for a set time period, 4 hours by default. The timer setting may be changed during setup of the unit on mobile device.  <b>Night mode:</b> the timer activates operation of the ventilation unit at Speed I for a set time period, 8 hours by default. The timer setting may be changed during setup of the unit on mobile device. The ventilation unit reverts to operation with a previous speed setting upon elapse of the set time period. Press any speed setting key to deactivate the timer or press the timer control button once again.

### REMOTE CONTROL OF THE VENTILATOR WITH A BLAUBERG HOME APP

Download the Blauberg Home application and install it on the mobile device.

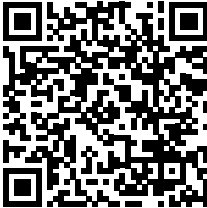
<a href="#">Blauberg Home – App Store</a>	<a href="#">Blauberg Home – Play Market</a>
	

The ventilator works as a Wi-Fi access point named FAN by default: + 16 ID Number characters) stated on the ventilator casing under the front panel.

**Wi-Fi access point password:** 11111111.

To connect, follow the instructions in the mobile app. In the app, you can configure the ventilator to connect via your home Wi-Fi network and via a cloud server.

### CONTROLLING THE VENTILATOR USING THE SMART HOME SYSTEM

The ventilators must be connected to the Smart home system in compliance with user's manual for this application.



### **WIRELESS CONNECTION OF SEVERAL VENTILATION UNITS**

The ventilators can be combined into a group in which one ventilator acts as a Master device and the others are connected to it as Slaves. If the ventilator is a Master unit, Slave units and mobile devices connect to it via Wi-Fi. The Master unit is operated by means of a mobile device, the remote control or the touch buttons on the unit casing. The control signal is automatically transmitted to all the Slave units in the network.

In this mode the unit responds to a signal from sensors (humidity sensor, external digital sensor, external analogue sensor 0-10 V) and changes its operation mode respectively.

If the ventilator is a Slave unit, it only receives control signals from the Master ventilator. Any other signals from other controls are ignored.

In this mode the VENTO Expert ventilators also ignore the sensor signals. In case of communication loss with the Master unit above 20 seconds, the unit switches to Standby mode.

#### **Sensor operation**

VENTO Expert ventilators only respond to sensor signals when they are in the master role.

VENTO Expert Duo ventilators always respond to sensor signals, regardless of their role in the group.

If any of the sensors in the VENTO Expert are triggered, all VENTO Expert ventilators in the group will go to maximum speed, while the VENTO Expert Duo ventilators continue to operate at the same speed.

If any of the sensors in the VENTO Expert Duo are triggered, only that ventilator goes to the maximum speed in the humidity control scenario, while the other ventilators in the network continue to run without increasing the speed.

**VENTILATOR WIRELESS CONNECTION DIAGRAMS**

**Wiring diagram 1**

Connection of up to 8 Slave units or mobile devices to the Master unit with its own wireless access point.  
If eight Slave ventilators are connected to a Master ventilator with a Wi-Fi access point you cannot connect a mobile device!

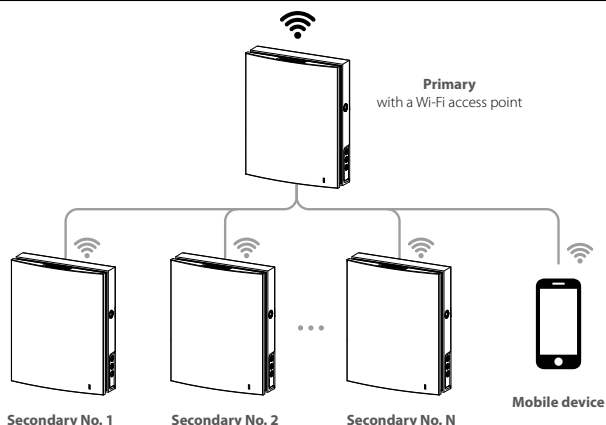

**Wiring diagram 2**

The Master units, the Slave units and the mobile devices are connected to a wireless access point of the Wi-Fi router. In this case, the Master unit can operate with the number (N) of Slave units, limited by the technical characteristics of the router.

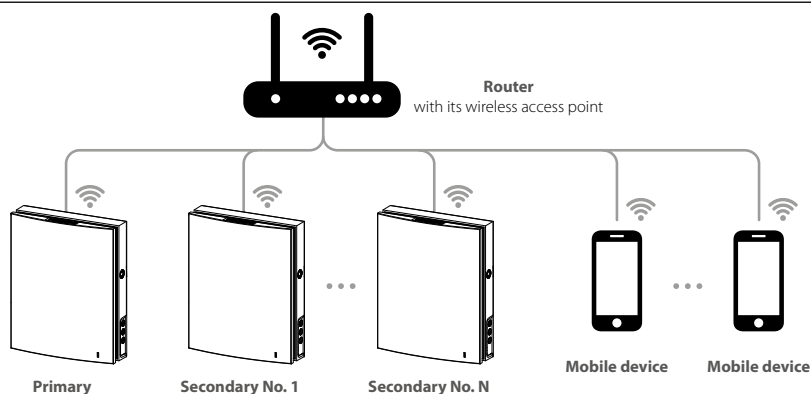

If the Wi-Fi router capacity is not enough to connect a required number of the units, you may use an extra wireless access point to connect the other the unit. Several Master units can optionally be connected to the network for arranging a zone control.

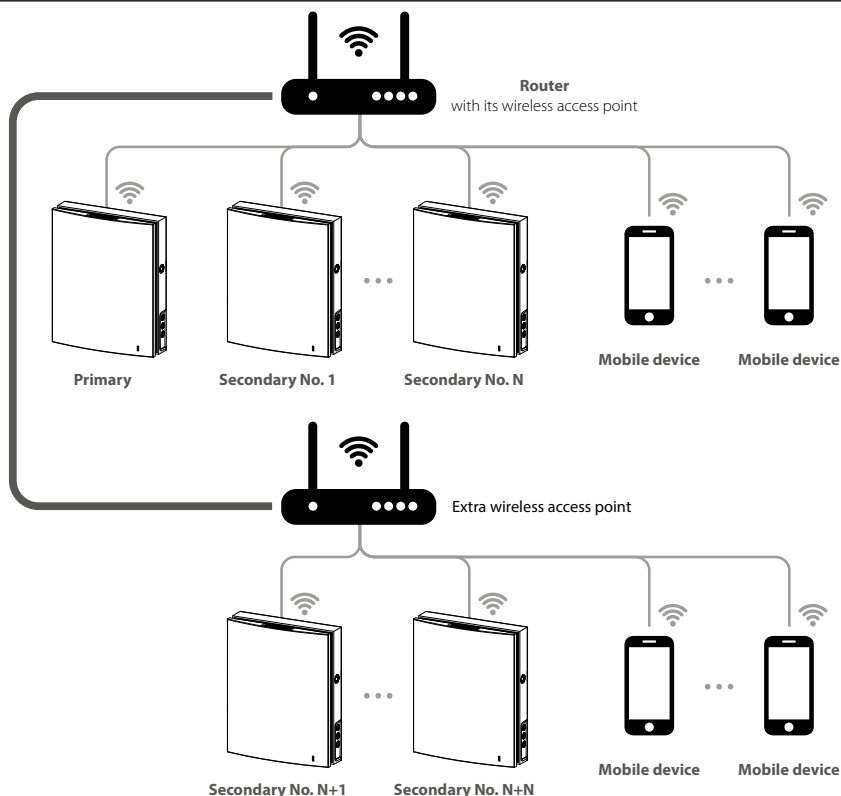

### SPECIAL SETUP MODE

In the event of losing the Wi-Fi password or the master ventilator password or in other cases, use the special Setup mode to restore access to the ventilator functions.

To enter the special Setup mode, press and hold the **Ventilation**  button on the ventilator casing for 5 seconds until the beep and blinking of all the LED lights.

The ventilator will continue in this mode for 3 minutes and then automatically revert to the previous settings.

To exit the Setup mode immediately, press and hold the **Ventilation**  button on the ventilator casing once again for 5 seconds until the beep and shutdown of all the LED lights.

In this mode the following settings are available for the Master unit:

- Wi-Fi network name: Setup mode.
- Wi-Fi password: 11111111.
- The unit password is ignored.



**WHEN SETTING UP THE CONNECTION OF THE DEVICES, IT IS NECESSARY THAT ALL SLAVE VENTILATORS ARE WITHIN THE WI-FI COVERAGE AREA OF THE MASTER VENTILATOR. AFTER CHANGING THE WI-FI PARAMETERS OF THE MASTER VENTILATOR, RECONNECT THE VENTILATORS**

### CONNECTING MASTER AND SLAVE VENTILATORS

To create a group of ventilators that are linked together as a Master and Slave, follow these steps:

- Set the DIP switches on each ventilator to the position that corresponds to its role in the group (see "DIP switch position").
- Then configure the Wi-Fi settings of the Master ventilator by following the instructions in the Blauberg Home mobile app.
- Set the Master ventilator to the special mode as described above, and all LEDs on the ventilator casing will start flashing. Repeat the steps with all the Slave units and wait for the beep when all the LED lights stop blinking on each Slave unit. Set the Master unit to the

normal operation mode. Press and hold the **Ventilation**  button.

**Note:** if the home router works in conjunction with several Wi-Fi access points requiring connection of ventilators to different access points:

- Connect the Master unit to the first Wi-Fi access point.
- Complete the connection with the first group of Slave units.
- Connect the Master unit to the second Wi-Fi access point.
- Complete the connection with the second group of Slave units.

### REPLACEMENT OF THE BATTERY

When the battery is low, the **Alarm** indicator on the unit casing will blink. The mobile app will also display the  warning and show the following message on pressing the indicator icon. Low battery power may cause disruptions in the weekly schedule operation. Power off the unit before replacing the battery. After replacing the battery reset the time and date.

The battery is located on the control board. To replace the battery, power off the ventilator, remove the front panel and the cover protecting the control circuit board. Remove the battery and install the new one.

The battery type is : **CR1220**.

**TECHNICAL MAINTENANCE**

**DISCONNECT THE UNIT FROM POWER SUPPLY BEFORE ANY MAINTENANCE OPERATIONS!**

**MAKE SURE THE UNIT IS DISCONNECTED FROM POWER MAINS BEFORE REMOVING THE PROTECTION.**

Maintenance of the ventilator means regular cleaning of the ventilator surfaces of dust and cleaning and replacement of the filters. To enable access to the main units, follow the procedure described below. The ventilator must be previously turned off using the remote control or the buttons on the indoor unit. Then turn off power supply completely.

**VENTO Expert**

1. Press the latches on the side of the indoor control unit to take off the front part.  
**Please make sure the thermal actuator rod is in lower position during re-installation of the front panel. If the thermal actuator rod is up, please wait for about 2 minutes until it goes down.**

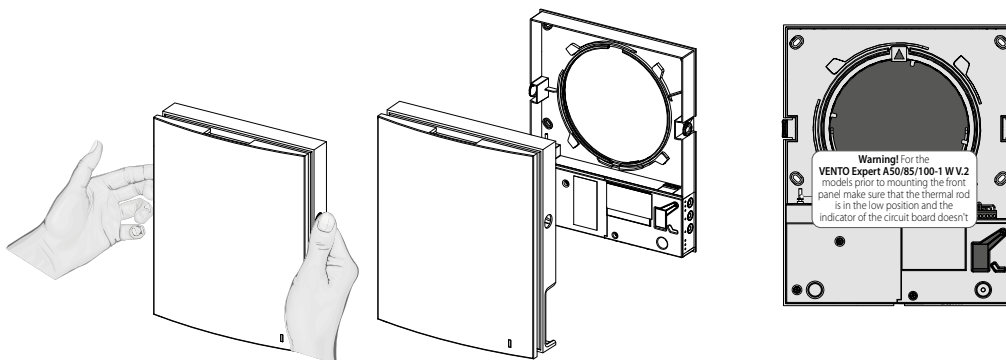

**VENTO Expert Duo**

1. Press the latches on the side of the indoor control unit to take off the front part. Then detach the front panel from the front part by gently unlatching the latches. Pull out the filters for cleaning. Reassemble in the reverse order.

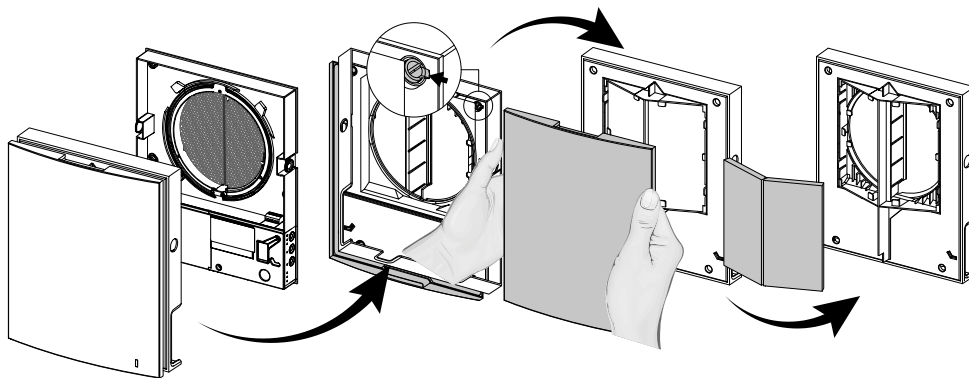

2. Disconnect the connector from the circuit board.  
Do not remove the connector by pulling the wires. Use a flat screwdriver to uplift it, if required.

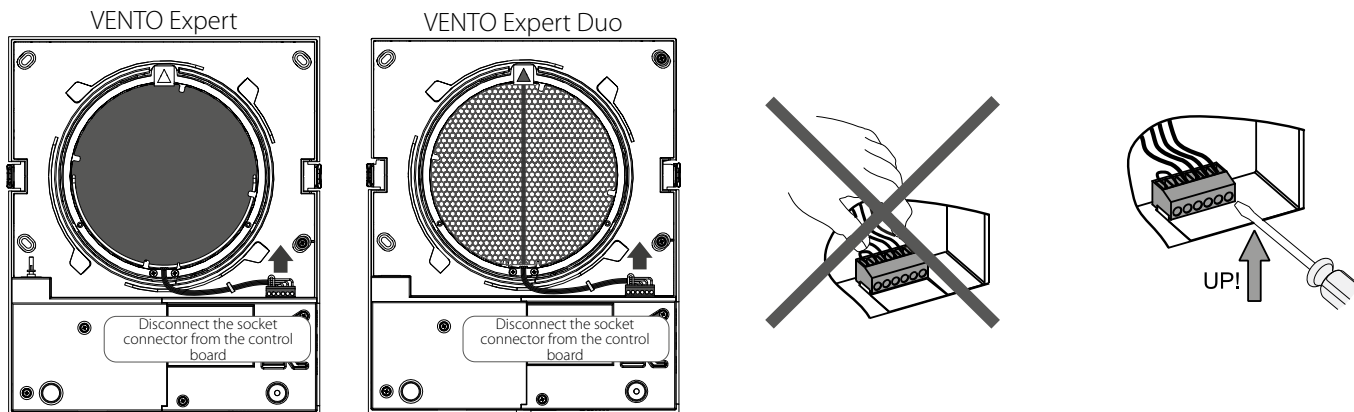

3. Pull the cord to remove the cartridge from the air duct.

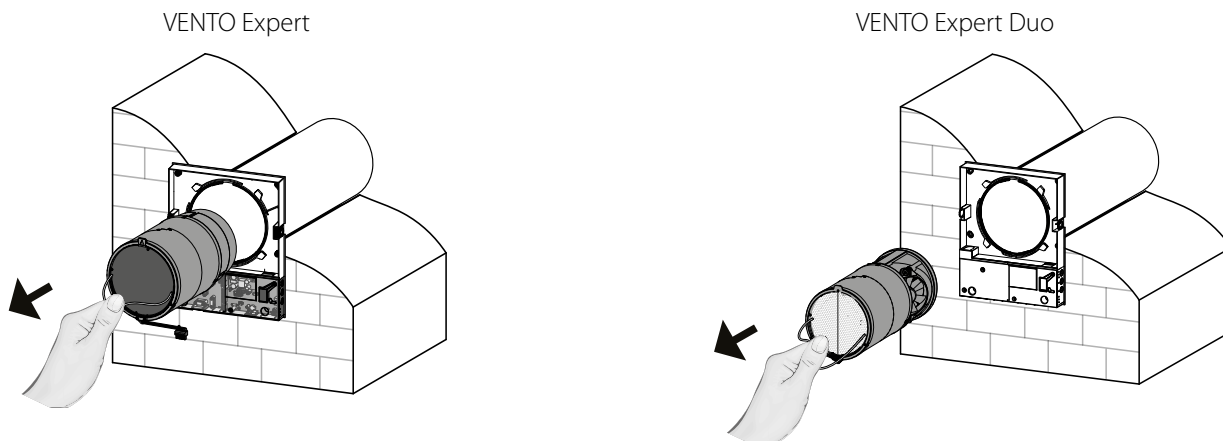

Clean the filters as often as required, but at least 3 times a year.

- Upon elapse of the set time period (factory setting 90 days) the filter replacement indicator (Filter) starts glowing. The filter timer is reset using the program on the mobile device.
- Wash the filters and let those dry out completely. Install the dry filters in their place and assemble the unit in the reverse order.
- Vacuum cleaning is allowed.
- The filter rated service life is 3 years.

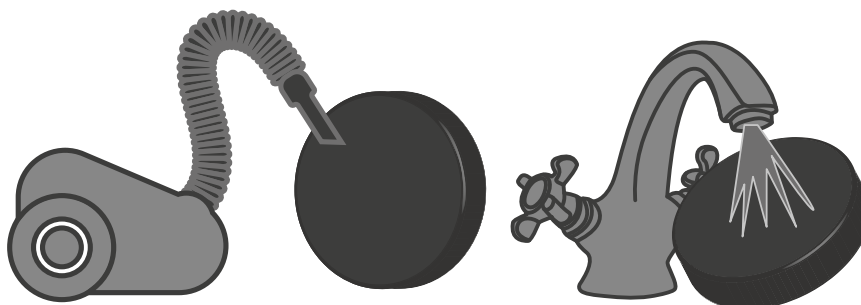

Some dust may accumulate on the heat exchanger block even in case of regular maintenance of the filters.

- Clean the regenerator regularly to ensure its high heat recovery efficiency.
- Vacuum clean the regenerator not less than once a year.

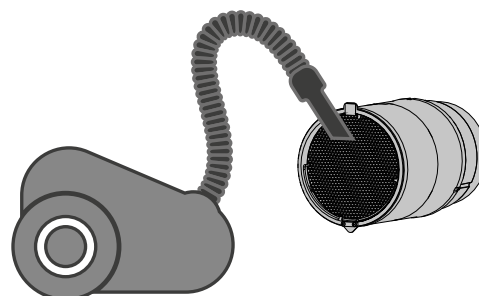

4. Replacing the battery in the remote control (when needed).

In case of a long operation of the remote control the battery must be replaced.

No response of the ventilator for pressing the remote control buttons indicates the need to replace the battery.

The battery type is CR2025.

Remove the holder with the battery from the lower part of the remote control.

Replace the battery and install the holder with a new battery back to the remote control.

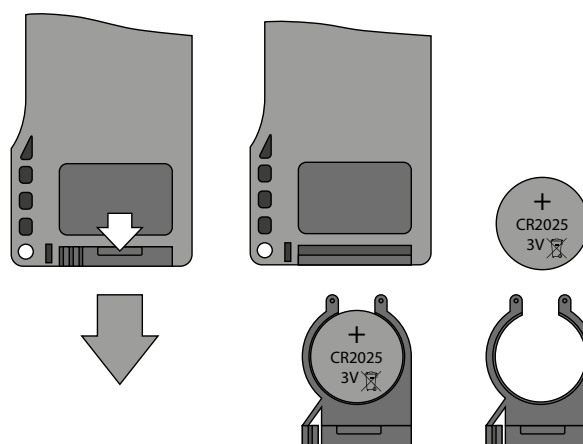

**POSSIBLE FAULTS AND TROUBLESHOOTING**

<b>Problem</b>	<b>Possible reasons</b>	<b>Troubleshooting</b>
When switching on the ventilator the fan does not start.	No power supply.	Make sure the power supply line is connected correctly, otherwise troubleshoot the connection error.
	The motor is jammed, the impeller blades are clogged.	Turn the ventilator off. Troubleshoot the motor jam and impeller clogging. Clean the blades. Turn the ventilator on.
Circuit breaker tripping during the ventilator start-up.	Overcurrent as a result of short circuit in the electric circuit.	Turn the ventilator off. Contact the Seller for further information.
Low air flow.	Low set fan speed.	Set higher speed.
	The filters, the fan or the regenerator are clogged.	Clean or replace the filter. Clean the fan and the heat exchanger.
Noise, vibration	The impeller is clogged.	Clean the impeller.
	Loose screw connection of the ventilator casing or the outer ventilation hood.	Tighten the screws of the ventilator or the outer ventilation hood.

**STORAGE AND TRANSPORTATION REGULATIONS**

- Store the unit in the manufacturer's original packaging box in a dry closed ventilated premise with temperature range from +5 °C to + 40 °C and relative humidity up to 70 %.
- Storage environment must not contain aggressive vapors and chemical mixtures provoking corrosion, insulation, and sealing deformation.
- Use suitable hoist machinery for handling and storage operations to prevent possible damage to the unit.
- Follow the handling requirements applicable for the particular type of cargo.
- The unit can be carried in the original packaging by any mode of transport provided proper protection against precipitation and mechanical damage. The unit must be transported only in the working position.
- Avoid sharp blows, scratches, or rough handling during loading and unloading.
- Prior to the initial power-up after transportation at low temperatures, allow the unit to warm up at operating temperature for at least 3-4 hours.

## MANUFACTURER'S WARRANTY

The product is in compliance with EU norms and standards on low voltage guidelines and electromagnetic compatibility. We hereby declare that the product complies with the provisions of Electromagnetic Compatibility (EMC) Directive 2014/30/EU of the European Parliament and of the Council, Low Voltage Directive (LVD) 2014/35/EU of the European Parliament and of the Council and CE-marking Council Directive 93/68/EEC. This certificate is issued following test carried out on samples of the product referred to above.

The manufacturer hereby warrants normal operation of the unit for 24 months after the retail sale date provided the user's observance of the transportation, storage, installation, and operation regulations. Should any malfunctions occur in the course of the unit operation through the Manufacturer's fault during the guaranteed period of operation, the user is entitled to get all the faults eliminated by the manufacturer by means of warranty repair at the factory free of charge. The warranty repair includes work specific to elimination of faults in the unit operation to ensure its intended use by the user within the guaranteed period of operation. The faults are eliminated by means of replacement or repair of the unit components or a specific part of such unit component.

### The warranty repair does not include:

- routine technical maintenance
- unit installation/dismantling
- unit setup

To benefit from warranty repair, the user must provide the unit, the user's manual with the purchase date stamp, and the payment paperwork certifying the purchase. The unit model must comply with the one stated in the user's manual. Contact the Seller for warranty service.

### The manufacturer's warranty does not apply to the following cases:

- User's failure to submit the unit with the entire delivery package as stated in the user's manual including submission with missing component parts previously dismantled by the user.
- Mismatch of the unit model and the brand name with the information stated on the unit packaging and in the user's manual.
- User's failure to ensure timely technical maintenance of the unit.
- External damage to the unit casing (excluding external modifications as required for installation) and internal components caused by the user.
- Redesign or engineering changes to the unit.
- Replacement and use of any assemblies, parts and components not approved by the manufacturer.
- Unit misuse.
- Violation of the unit installation regulations by the user.
- Violation of the unit control regulations by the user.
- Unit connection to power mains with a voltage different from the one stated in the user's manual.
- Unit breakdown due to voltage surges in power mains.
- Discretionary repair of the unit by the user.
- Unit repair by any persons without the manufacturer's authorization.
- Expiration of the unit warranty period.
- Violation of the unit transportation regulations by the user.
- Violation of the unit storage regulations by the user.
- Wrongful actions against the unit committed by third parties.
- Unit breakdown due to circumstances of insuperable force (fire, flood, earthquake, war, hostilities of any kind, blockades).
- Missing seals if provided by the user's manual.
- Failure to submit the user's manual with the unit purchase date stamp.
- Missing payment paperwork certifying the unit purchase.



**FOLLOWING THE REGULATIONS STIPULATED HEREIN WILL ENSURE A LONG AND TROUBLE-FREE OPERATION OF THE UNIT**



**USER'S WARRANTY CLAIMS SHALL BE SUBJECT TO REVIEW ONLY UPON PRESENTATION OF THE UNIT, THE PAYMENT DOCUMENT AND THE USER'S MANUAL WITH THE PURCHASE DATE STAMP**









**CERTIFICATE OF ACCEPTANCE**

<b>Unit Type</b>	Single-room reversible energy recovery ventilator
<b>Model</b>	
<b>Serial Number</b>	
<b>Manufacture Date</b>	
<b>Quality Inspector's Stamp</b>	

**SELLER INFORMATION**

<b>Seller</b>	
<b>Address</b>	
<b>Phone Number</b>	
<b>E-mail</b>	
<b>Purchase Date</b>	
This is to certify acceptance of the complete unit delivery with the user's manual. The warranty terms are acknowledged and accepted.	
<b>Customer's Signature</b>	

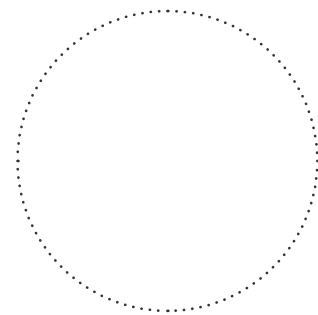

Seller's Stamp

**INSTALLATION CERTIFICATE**

The _____ unit is installed pursuant to the requirements stated in the present user's manual.	
<b>Company name</b>	
<b>Address</b>	
<b>Phone Number</b>	
<b>Installation Technician's Full Name</b>	
<b>Installation Date:</b>	<b>Signature:</b>
The unit has been installed in accordance with the provisions of all the applicable local and national construction, electrical and technical codes and standards. The unit operates normally as intended by the manufacturer.	
<b>Signature:</b>	

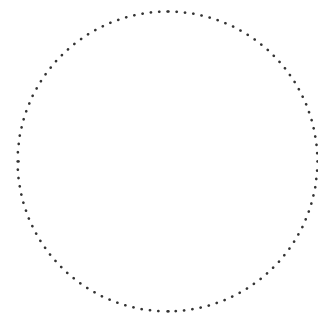

Installation Stamp

**WARRANTY CARD**

<b>Unit Type</b>	Single-room reversible energy recovery ventilator
<b>Model</b>	
<b>Serial Number</b>	
<b>Manufacture Date</b>	
<b>Purchase Date</b>	
<b>Warranty Period</b>	
<b>Seller</b>	

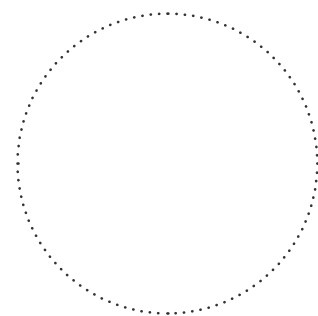

Seller's Stamp

